

IR FLAME DETECTOR

RIV-601P/F

EN 54-10 class 1
VdS approval G 211093
EC-certificate of conformity no. 0786 - CPD - 21103

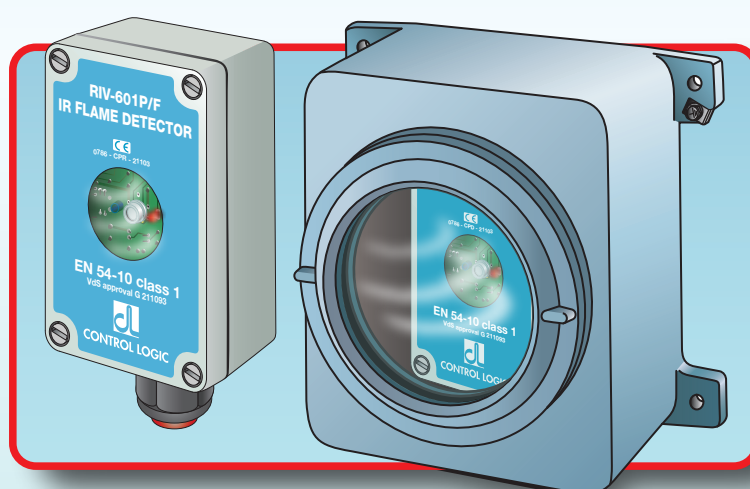

application manual



ISO 9001



CONTROL LOGIC



IR FLAME DETECTORS

SUMMARY

	Page
● RIV-601P/F general notions	3
● RIV-601P/F description.....	4
● Electrical and general characteristics	5
● RIV-601P/F inside view	6
● RIV-601P/F mechanical dimensions.....	7
● RIV-601P/FA explosion-proof model with SOA-875 variable direction stand	8
● RIV-601P/F Operation.....	9
● RIV-601P/F flame detector applications:	
A Vertical application with FULL area coverage	10
B Vertical application with PARTIAL area coverage	11
C Diagonal application with FULL area coverage	12
D Vertical application of two detectors with FULL area coverage	13
E Diagonal application of two detectors with FULL area coverage	14
F Vertical application over pole with FULL area coverage	15
● RIV-601P/F electrical connections	16
● RIV-601P/F remote test function	17
● RIV-601P/F automatic remote fault warning	18
● Attenuation optical filter for RIV-601P/F	19
● SOR-876 variable direction stand for IR Flame Detector RIV-601P/F	20
● EN 54-10 VdS Approval no. G 211093	21
● Standard EN 54-10 EC-certificate of conformity no. 0786 - CPD - 21103	22

IR FLAME DETECTOR RIV-601P/F

General notions

The IR flame detector model RIV-601P/F is an electronic optical fire detector device that responds immediately to the thermal infrared radiation emitted by fire, and is tuned to the pulse frequency of the flame to ignore sun, lamps and other light and infrared radiation sources.

WHY IR (infrared) FLAME DETECTOR

Eye is faster than nose. In the event of live fire the IR flame detector responds immediately. Its behaviour is similar to that of the eye. In fact it "sees" the radiation emitted by fire, and its sensitivity is inside a cone of 90° which is called the field of view.

The minimum flame size that can be detected by the RIV-601P/F varies with the distance. It doubles at double distance and is half at half distance. The sensitivity value is 2-3% of the distance. For example, at 10m the smallest detectable flame size is 20-30cm.

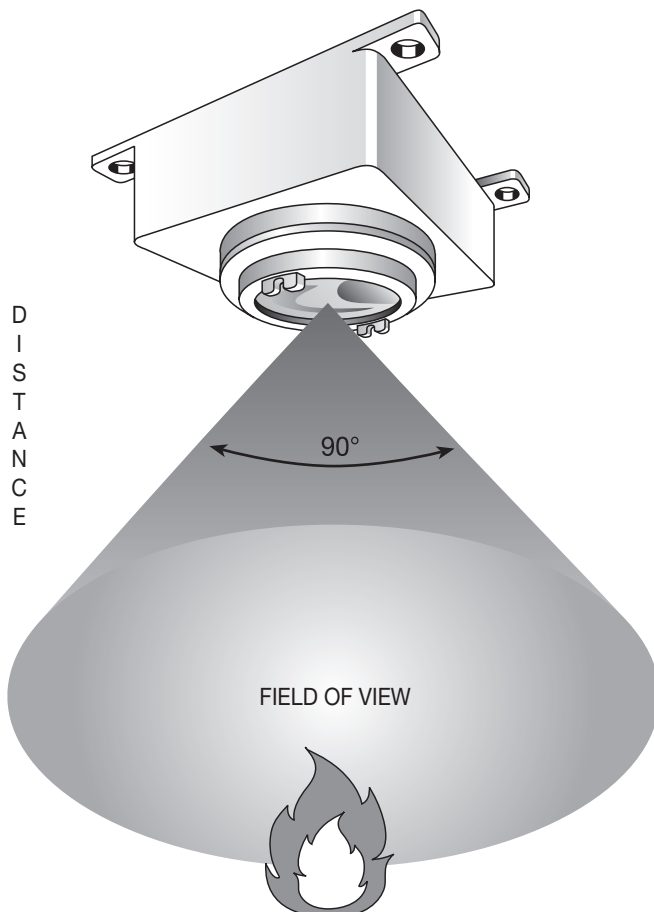

WHY IR (infrared) RADIATION

The visible radiation emitted by fire is just a small amount of the emitted energy. The most part is comprised of invisible thermal infrared radiation, typically emitted by all hot bodies, with a wavelength varying with the body temperature.

At higher temperature a shorter wavelength is generated and viceversa. The IR flame detector sees very well this IR radiation but is near blind to the visible light. Furthermore the thermal infrared radiation passes through the smoke, while the light does not. For this reason the IR flame detector responds to the fire also when smoke is present.

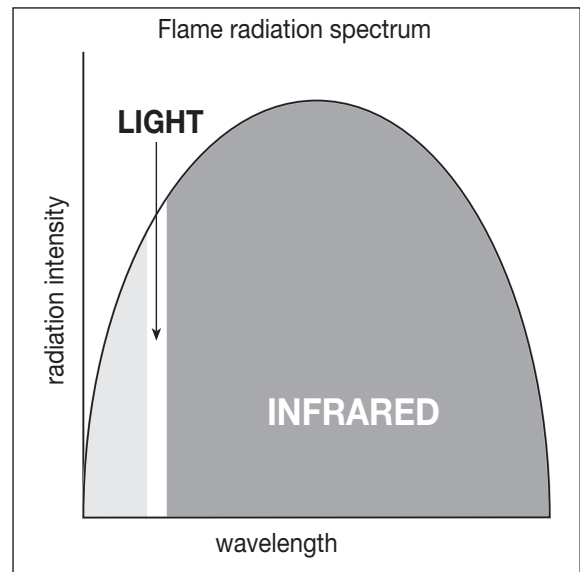

WHY IT DOES NOT RESPOND TO THE SUNLIGHT AND LAMPS

Sun and lamps also generate thermal infrared radiation. But flame is different because it flickers at a particular frequency in the range from 3 to 30 Hz (pulses per second). The IR flame detector is tuned to this pulsing radiation like a radio receiver is tuned to one station and ignores all others. Nevertheless direct exposition to the sunlight and lamps must be avoided, since it causes the detector to become blind or give false alarms.

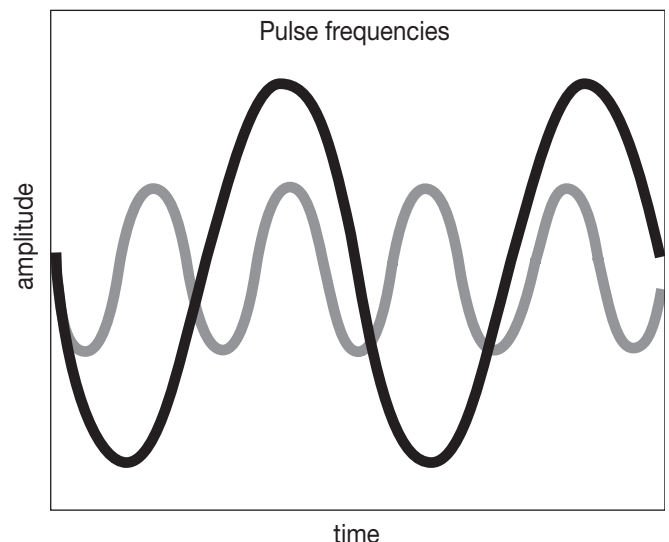

IR FLAME DETECTOR RIV-601P/F

DESCRIPTION

The IR flame detector model RIV-601P/F is an electronic optical fire detecting device which responds immediately to the thermal infrared radiation emitted by fire and is tuned to the flickering frequency of the flame to ignore sun and lamp light.

It is enclosed in a cast aluminium **watertight case** with **IP66** grade protection, which allows to withstand dusty environment and rain.

An **IP66 explosion-proof enclosure** is provided for the RIV-601P/FA model.

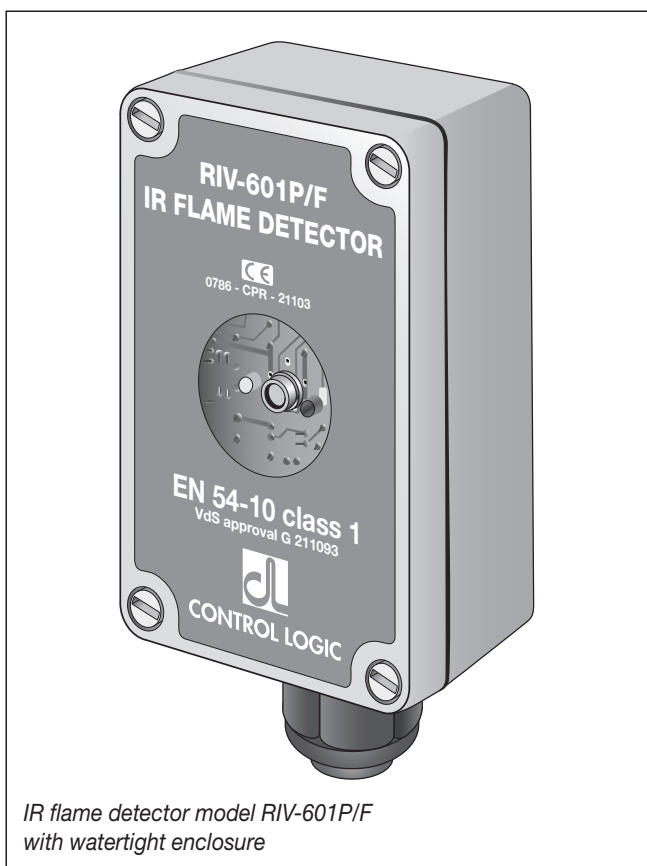

*IR flame detector model RIV-601P/F
with watertight enclosure*

Nominal 24Vdc input power is required, with wide span allowed, and two different outputs are provided: one heavy changeover relay contact, and one NPN transistor open collector. Both outputs go into alarm state after a pre-set time delay, but they come back to the stand-by state as soon as the fire stops. The delay time is normally set to 5 seconds, but can be set in the range from 1 to 10 seconds. A protection against the 24Vdc power voltage inversion is provided. Sensitivity is 2-3% of the distance, that means a 10cm flame at 5m distance, or a 20cm flame at 10m. The field of view is a 90° cone, but beyond 90° the detector can see with reduced sensitivity, and can also see behind obstacles due to reflections.

A small dust build-up over the detector window does not decrease too much the detector ability, since thermal infrared radiation is little attenuated by dust, much less than light is. Therefore a frequent window cleaning is not required.

Also smoke does not blind the detector, which is operating well with fires in heavy smoke.

It is equipped with the “**teletest**” device for remote monitoring of detector.

This device simulates a flame inside the detector so as to stimulate a sensor response like to a real fire.

The teletest device includes an incandescent bulb and a modulator circuit that generates a pulsating thermal infrared radiation in front of the sensor.

The teletest can be manually controlled from a remote site, or it can be automatic and continuously running.

The detector response to the teletest is a short alarm pulse of half a second every 4 seconds during all the period the teletest is operated. These short pulses can be recognised by the control panel as a state of live stand-by, since the real fire alarm is continuous. If pulses stop, this means a detector failure or the power voltage is off.

A front red LED lamp will signal the detector stand-by or alarm state.

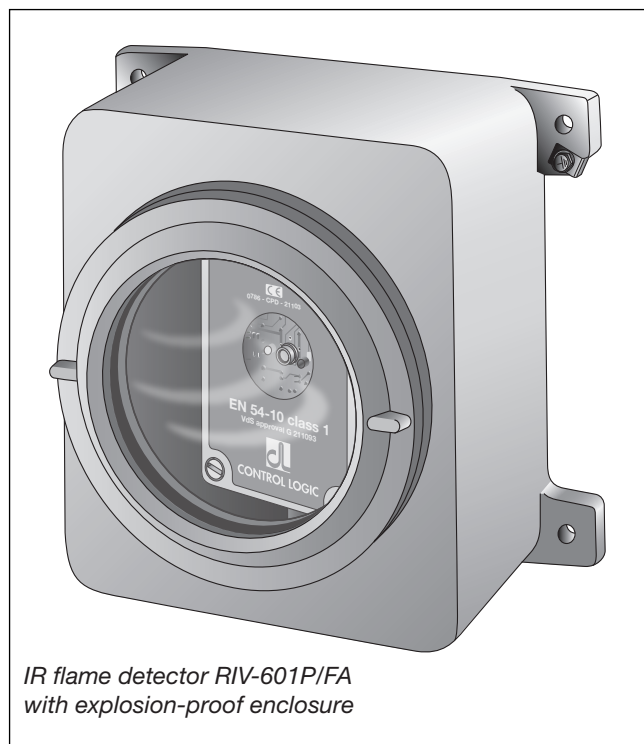

*IR flame detector RIV-601P/FA
with explosion-proof enclosure*

Normally the detector is installed vertically, centred on the area to be covered, so as the 90° cone field of view can be fully used. The ideal height is 0.7 the side of the square area.

For instance, if side is 10m, then height is 7m and maximum viewing distance is 10m.

If ceiling is lower, corners are the ideal alternative.

In this case the height can be one third of the side.

Direct viewing of sun and bright lamps must be avoided, since this can blind the detector.

In outdoor applications a small hood or roof will help.

Vibrating or oscillating mounting must be avoided, since this can be a cause of false alarms.

IR FLAME DETECTOR MODEL RIV-601P/F watertight enclosure ELECTRICAL AND GENERAL SPECIFICATIONS

- Cast aluminium watertight case, **IP66** grade protection (dust and water spray). Explosion-proof available with the model RIV-601P/FA.
- Power voltage 24Vdc +/-15% (20 to 28V).
- Current consumption 13mA in stand-by (0.25W), 50mA in alarm state (max 1.5W including 20mA for test).
- Anti-inversion diode on +24V and + Test (**T+**).
- Spectral response infrared 1 to 3 micron.
- Tuned to flame pulsing frequency (flickering).
- Field of view 90° cone. The detector can see outside the field of view or indirectly by reflection, or even through smoke, with a reduced sensitivity.
- Sensitivity 2-3% of the distance, which means that the smallest detectable flame size is 2-3% of the distance. For example, at 10m the smallest flame size is 20cm. Typical covering figure is 400 square meters at 20m distance.
- Alarm delay time set to 5 sec. Adjustable from 1 to 10 sec. Reset is automatic. The detector turns on 5 seconds after the flame is started. As soon as the flame stops, the detector returns off.
- Front LED lamp lights in alarm. It blinks shortly during the teletest.
- Output on changeover SPDT relay contact rated 1A 30Vdc. Other output on NPN transistor open collector rated 50mA 24Vdc, which goes low in alarm.
- Built-in "Teletest" device for the remote monitoring of the detector ability. Needs a 24Vdc +/-15% 20mA. Built-in modulator. When the teletest circuit is powered, a small incandescent bulb placed near the sensor starts pulsing so as to simulate a flame. During the test the detector turns on for half a second every 4 seconds. The teletest can be remotely controlled from the control panel, or can be wired for a continuous and automatic operation. Control panel must recognise the short test pulses from the alarm state, which is steady on.
- Electrical wiring on 7 way terminal block, plug-in type, 10 pitch, wire size 2,5mm² max (a max 1,5mm² wire gauge is suggested to avoid a difficult wire entry into the screw terminal).
- Cable entry fitting M25 internal diameter 13-18mm.
- Operating temperature -20 +60°C.
- Storage temperature -40 +85°C.
- Dimensions 180x85x65(H) mm (mounting holes 125x70mm).
- Weight 700 grams.
- Manufactured in compliance with the essential requirements of the CPR Regulation.
- EN 54-10 class 1 approved, EC-certificate of conformity no. 0786-CPD-21103, VdS Approval no. G 211093.

Note:

1. It is highly recommended to connect the enclosure base to a good ground line using the **ground** terminal provided inside up on the left. Then, connect base and cover using the ground terminal provided inside the base lower on the right and the ground terminal provided inside the cover lower on the left.

All the ground terminals are signaled by ground label.

The ground connection must be done using a yellow-green conductor and a M4 double crimp eyelet.

The yellow-green ground conductor must be longer than the other conductors.

2. In order to ensure an **IP66 protection grade** the cover must be tightly closed turning the four screws provided. The suggested closing torque value is 1 ÷ 1,5 Nm.

IR FLAME DETECTOR MODEL RIV-601P/FA explosionproof enclosure DESCRIPTION AND SPECIFICATIONS

All same as for RIV-601P/F model except:

- Cast aluminium explosion-proof enclosure **ADF-600AP** model. External grey epoxy paint RAL7000 and internal anti-condensing orange paint RAL2004.
- Type of protection II 2 GD Ex d IIC T6 Ex tb IIIC T85°C IP66 (85°C max case temperature, referred to 40°C ambient).
- Conforms to ATEX Directive, BVI 14 ATEX 0007 certificate.
- Dimensions: mm. 225x255x170h main body only (mounting holes 260x220 – overall dimensions 290x255).
- Weight: kg. 10,5 case only - kg. 11,5 with detector inside.
- Sensitivity reduced to 4% of the distance.
- 1" Gas cable entry.

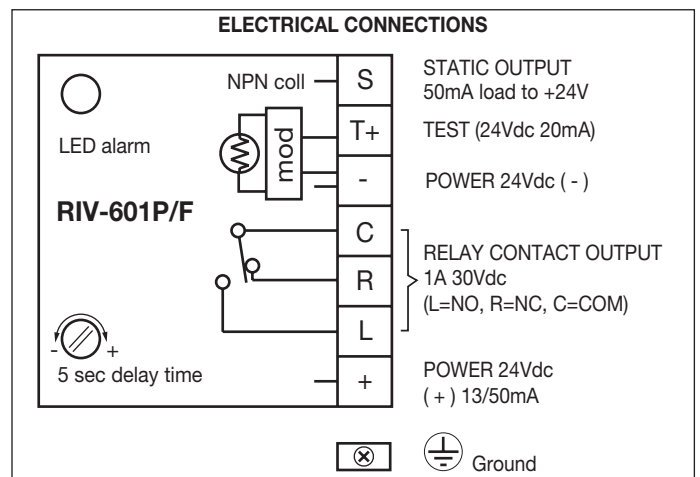

MECHANICAL DIMENSIONS

RIV-601P/F watertight enclosure

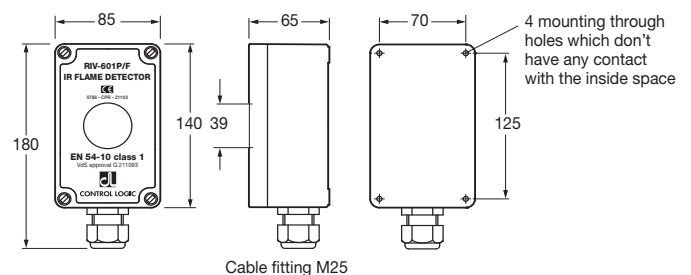

RIV-601P/FA with explosionproof enclosure ADF-600AP

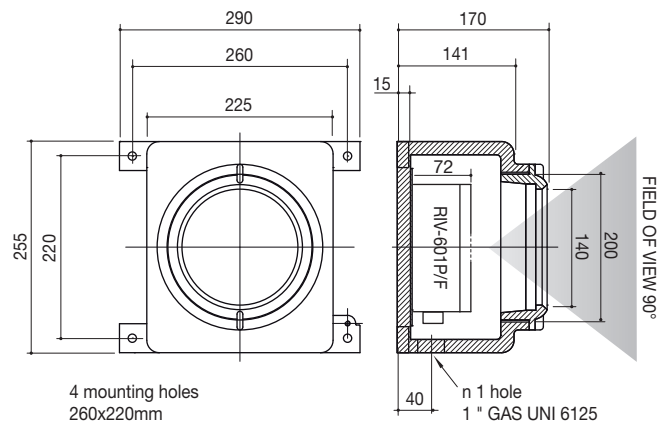

Note: In the model RIV-601P/FA the detector RIV-601P/F is to be mounted inside the explosionproof case by the customer during the installation phase, through the front window, over the steel plate provided on the bottom.

RIV-601P/F IR FLAME DETECTOR

Inside view

After the enclosure is opened, the inside view looks as follows:

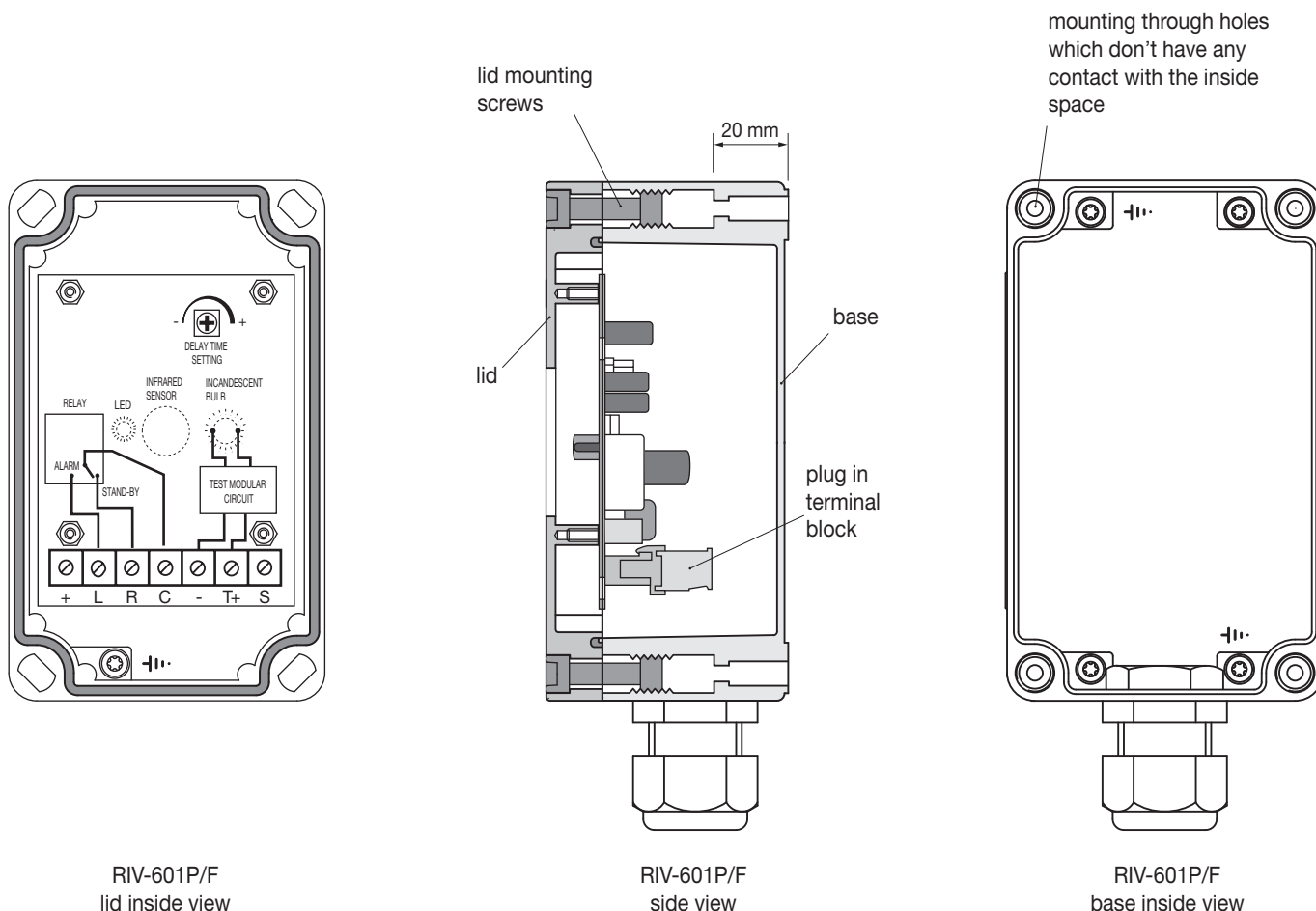

RIV-601P/F
lid inside view

RIV-601P/F
side view

RIV-601P/F
base inside view

The enclosure base part has four mounting holes.

On the enclosure base you can find both two ground screws and the cable entry fitting M25.

On the circuit board, which is placed inside the enclosure lid, the following parts are present: the alarm delay time setting potentiometer, which can be set by turning the centre screw, and the alarm relay.

The delay time setting increases by turning clockwise, and decreases anticlockwise. The standard value is 5 sec. The full range is from 1 to 10 sec.

Under the circuit board you find the infrared sensor, the red LED alarm lamp and a small incandescent bulb which simulates a flame when the test circuit is powered, all placed just behind the optical window.

The 7 way terminal block, plug-in type, has each function printed on the top of every terminal and on the circuit board just before the connector.

Note:

- It is highly recommended to connect the enclosure base to a good ground line using the **ground** terminal provided inside up on the left. Then, connect base and cover using the ground terminal provided inside the base lower on the right and the ground terminal provided inside the cover lower on the left.

All the ground terminals are signaled by ground label. ⊕

The ground connection must be done using a yellow-green conductor and a M4 double crimp eyelet.

The yellow-green ground conductor must be longer than the other conductors.

- In order to ensure an **IP66 protection grade** the cover must be tightly closed turning the four screws provided. The suggested closing torque value is 1 ÷ 1,5 Nm.

RIV-601P/F IR flame detector mechanical dimensions

- IP66 grade protection (dust and water spray).
- Dimensions 180x85x65(H)mm (mounting holes 125x70mm).
- Weight 700grams.

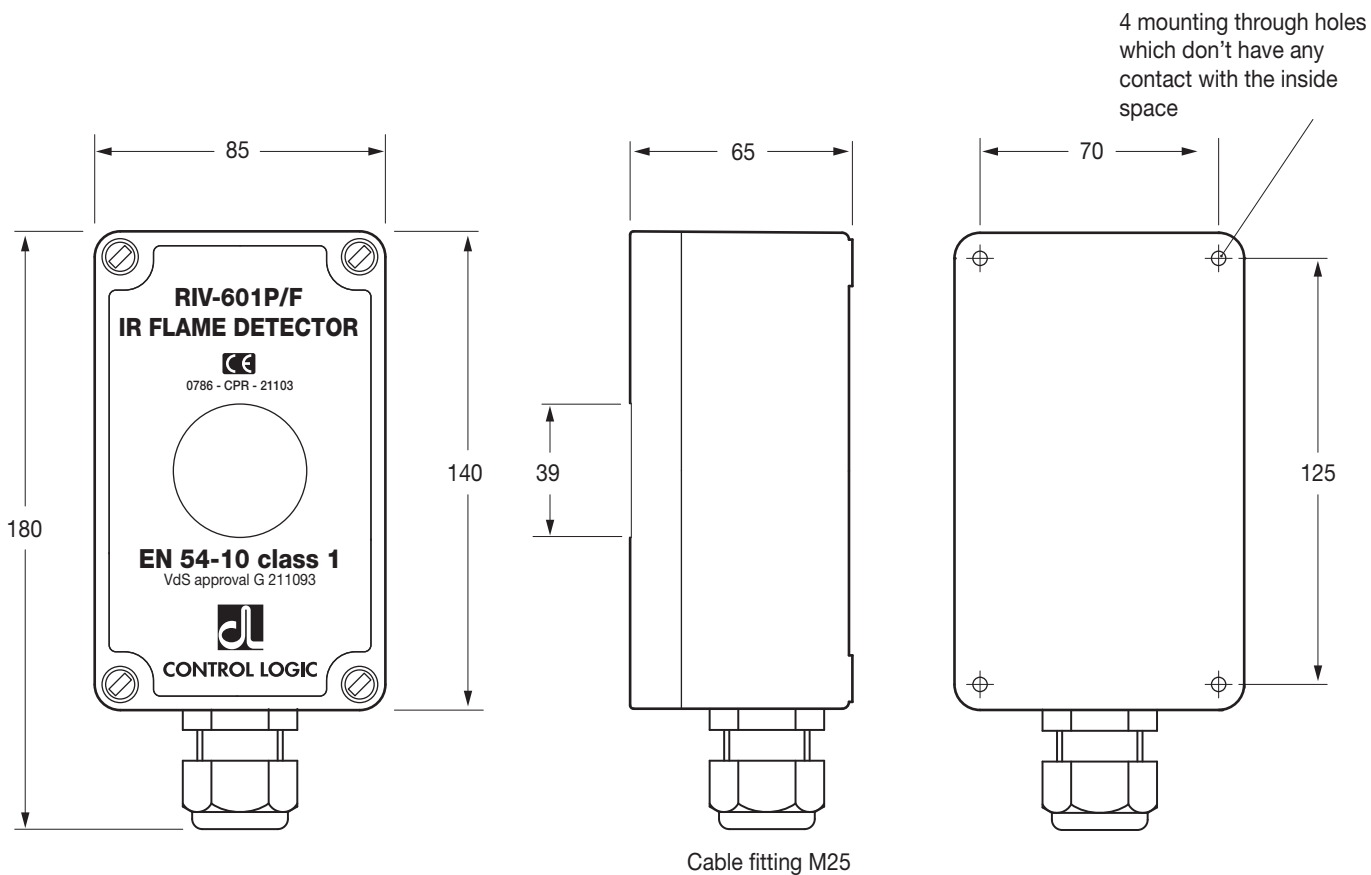

The RIV-601P/F shipping package includes:

- 1 RIV-601P/F infrared flame detector unit
- technical information

RIV-601P/FA IR Flame detector explosion-proof model RIV-601P/F model plus ADF-600AP explosion-proof enclosure

The explosion proof model RIV-601P/FA is made by mounting the watertight model RIV-601P/F inside the explosion-proof case.

The RIV-601P/FA shipping package includes:

- 1 IR flame detector model RIV-601P/F
- 1 explosion-proof enclosure model ADF-600AP
- 1 set technical information

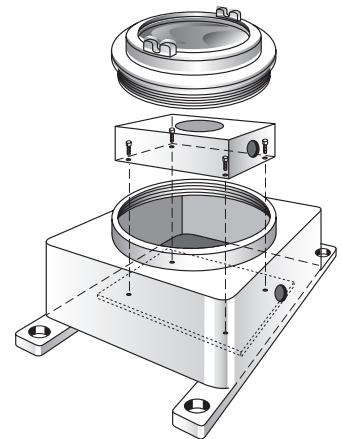

ADF-600AP explosion-proof enclosure

- Cast aluminium external grey epoxy paint (RAL 7000), internal anti-condensing orange paint (RAL 2004).
- Type of protection II 2 GD Ex d IIC T6 Ex tb IIIC T85°C IP66 (85°C max case temperature, referred to 40°C ambient).
- Conforms to ATEX Directive, BVI 14 ATEX 0007 certificate.
- Dimensions: mm. 225x255x170h main body only (mounting holes 260x220 - overall dimensions 290x255).
- Weight: kg 10,5 case only - kg 11,5 with detector inside.
- Sensitivity reduced to 4% of the distance.
- 1" Gas cable entry.

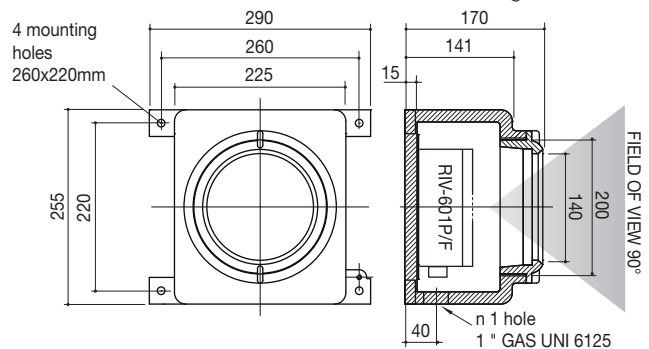

SOA-875

Variable direction stand for IR explosion-proof Flame Detector RIV-601P/FA

Description

The Variable Direction Stand SOA-875 is a useful accessory for installing IR Explosion-Proof Flame Detector RIV-601P/FA when an easy change of direction of the optical field of view towards the area of interest is needed.

It is composed of a steering arm with both horizontal and vertical steering, and of a base plate designed for IR Explosion-Proof Flame Detector RIV-601P/FA mounting.

The Variable Direction Stand and the screw parts are made of stainless steel, and can be used in outdoor applications.

Specifications

- Steering range: horizontal 360° vertical ± 90°
- Dimensions: 270x129x72mm
- Material: AISI 316L polished stainless steel
- Total weight: kg 2,500 net - 2,800 gross

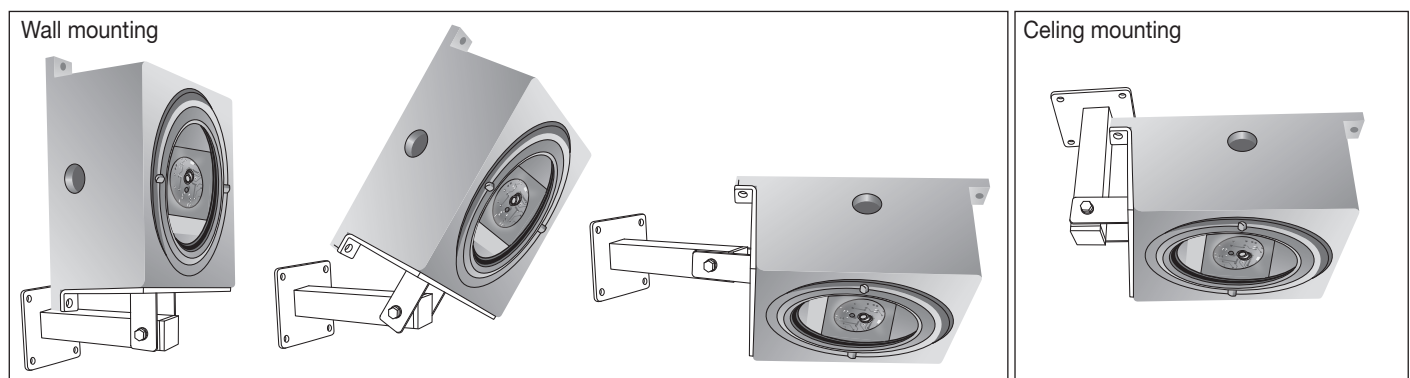
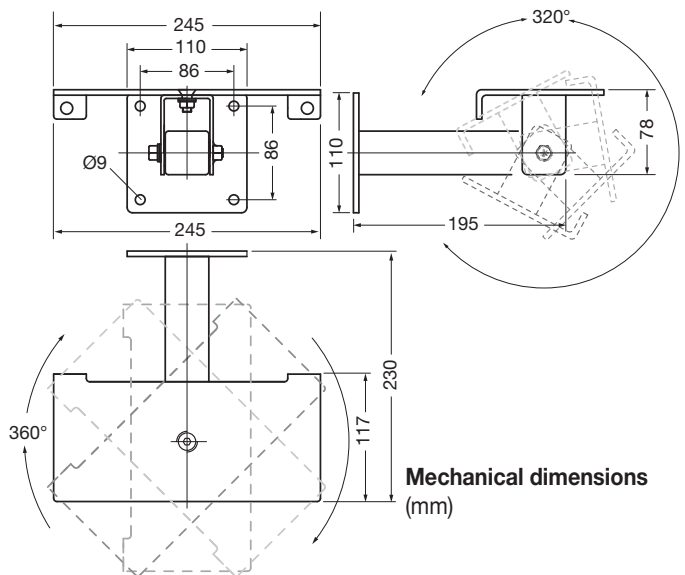

RIV-601P/F IR flame detector operation

The RIV-601P/F infrared Flame Detector turns on into the alarm state after a pre-set delay time (waiting time) from the moment a flame is started and is seen inside the 90° field of view.

As soon as the flame stops, the detector returns back to the stand-by state.

If the flame duration is less than the delay time, then the detector never reaches the alarm state and the time count is reset to zero.

The delay time is set to 5 sec. during production. It can be adjusted within the setting range of 1 to 10 sec. by the customer during the installation by turning the one-turn screwdriver potentiometer.

The detector field of view is a 90° cone, starting at the optical window centre.

Outside the field of view the detector sensitivity is lower but not zero, due to reflection from walls and objects. For the same reason the detector can see behind obstacles.

This flame detector can be used for all the applications, indoors and outdoors, where there is a high risk of fast spreading fire (fuels, flammable liquids, etc.), and an immediate alarm is required.

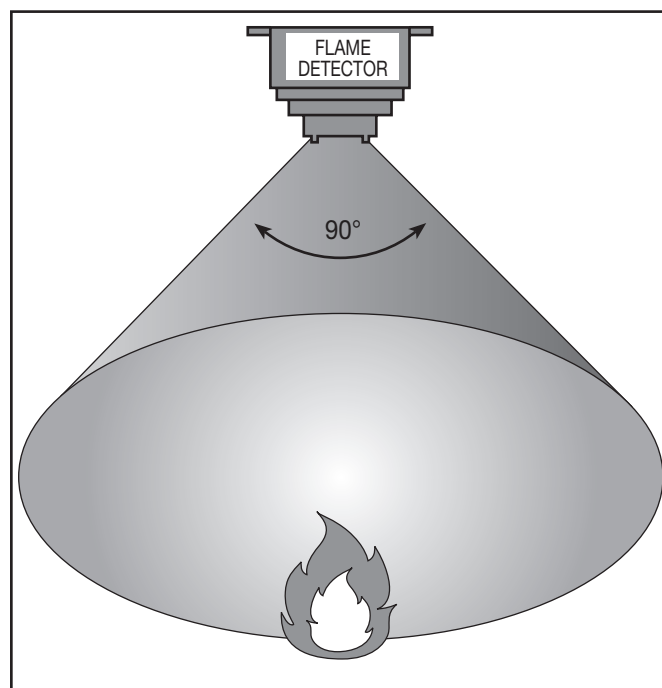
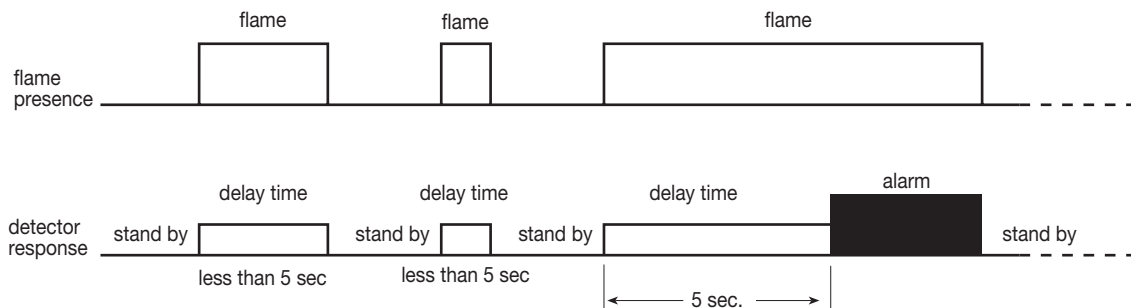

RIV-601P/F

IR flame detector applications

Mounting information

The waterproof model RIV-601P/F can be installed without any bracket by means of four screws.
The explosion-proof model RIV-601P/FA is made by mounting the model RIV-601P/F inside the explosion-proof enclosure model ADF-600AP. It will be installed on the requested position using the four screws included in the package.

For example, from a height of 10 m a floor area of 14x14m can be controlled.

This sort of installation uses the full detector field of view, that is the best one.

All floor area is covered.

Since the detector sensitivity is 2% of the distance (4% for the explosion-proof model), the smallest detectable flame size is 20cm at the centre where the distance is 10m, and 28cm at the corner where the distance is 14m.

A - Vertical application with FULL area coverage.

The detector must be installed over the area to be monitored, looking down vertically on the centre, at a height that is 0.7 times the side of the area (square).

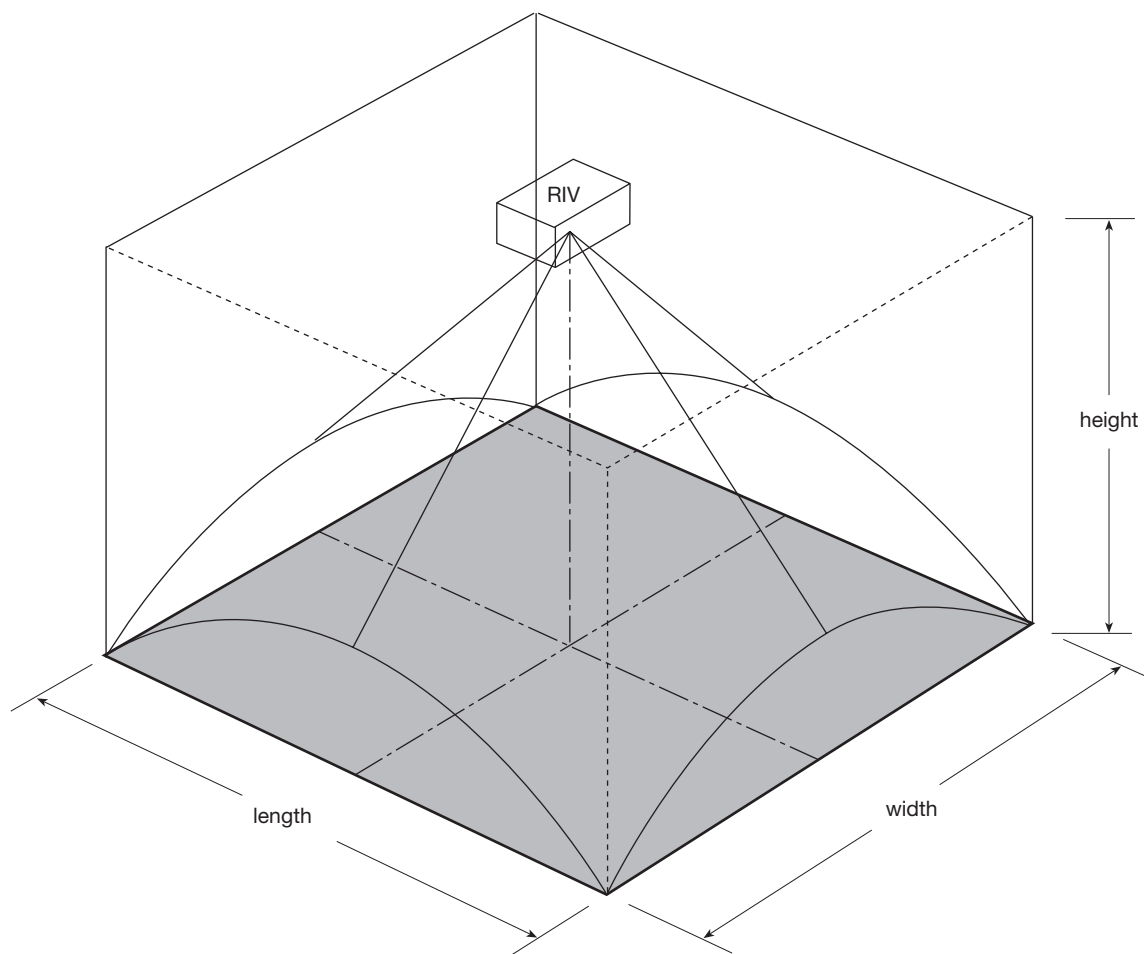

Note:

Remember that the detector sensitivity is 2% of the distance, while 4% for the explosion-proof model

RIV-601P/F

IR flame detector applications

B - Vertical application with **PARTIAL** area coverage

When ceiling is low or not high enough for full coverage, the centre vertical mounting is anyway used, provided only small corner areas are out of the detector field of view, and these small areas are not under risk of fire.

For example, a room 10m high with a floor of 16x20m is almost completely under the detector field of view. Only four small areas on the corners are out.

The smallest detectable flame size is 20 cm on the centre (2% of 10m distance) and 28cm on the border (2% of 14m distance).

The limit of this application could be a room 10m high with a floor of 20x20m, where the cone field of view base circle touches the floor sides. In this case the side length is 2 times as much as the ceiling height, and the smallest detectable flame size is 28cm in the worst case (2% of 14m distance).

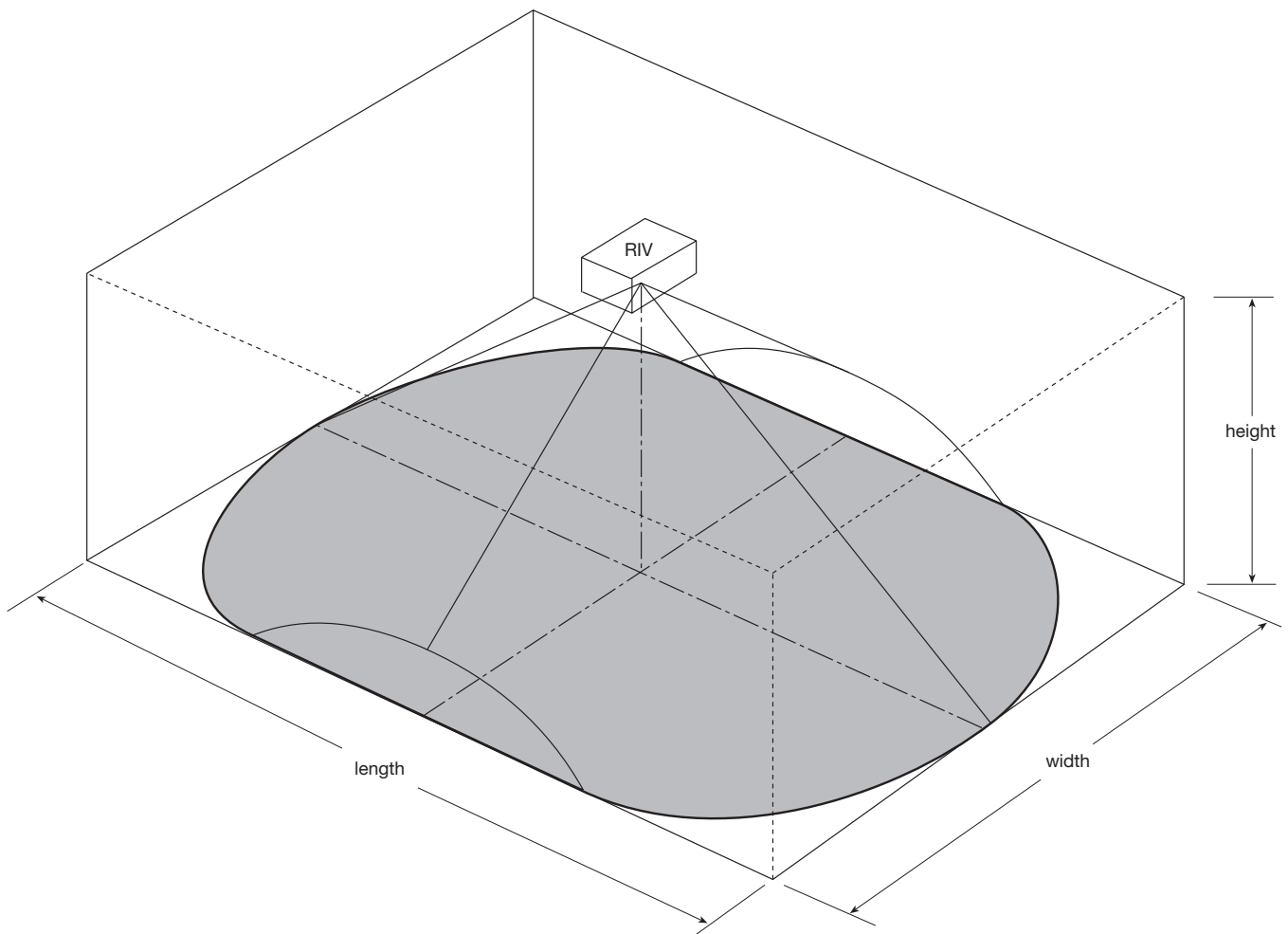

Note:

Remember that the detector sensitivity is 2% of the distance, while 4% for the explosion-proof model

RIV-601P/F

IR flame detector applications

C - Diagonal application with FULL area coverage

When ceiling is too low for full area coverage with centre vertical mounting, and only one detector is preferred, then the detector can be mounted on a ceiling corner so as it looks diagonally down 45° towards the floor.

For example, a room 10m high with a floor of 16x20m is fully under the detector field of view.

The smallest detectable flame size is 20cm under the detector corner (2% of 10m distance) and 55cm on the most distant floor corner (2% of 27.5m distance).

As you see, the smallest flame on the opposite corner is more than two times as much as under the detector corner. This disadvantage must be considered when choosing this type of application.

Also, the diagonal mounting makes the detector seeing other strong infrared lights entering into its field of view, like lamps and sun, which can cause false alarms. It is recommended to properly choose the detector position in order to avoid false alarms.

The limit of this application could be a room 10m high with a floor of 30x30m. In this case the side length is 3 times as much as the ceiling height, and the smallest detectable flame size is 80cm in the worst case (2% of 40m distance).

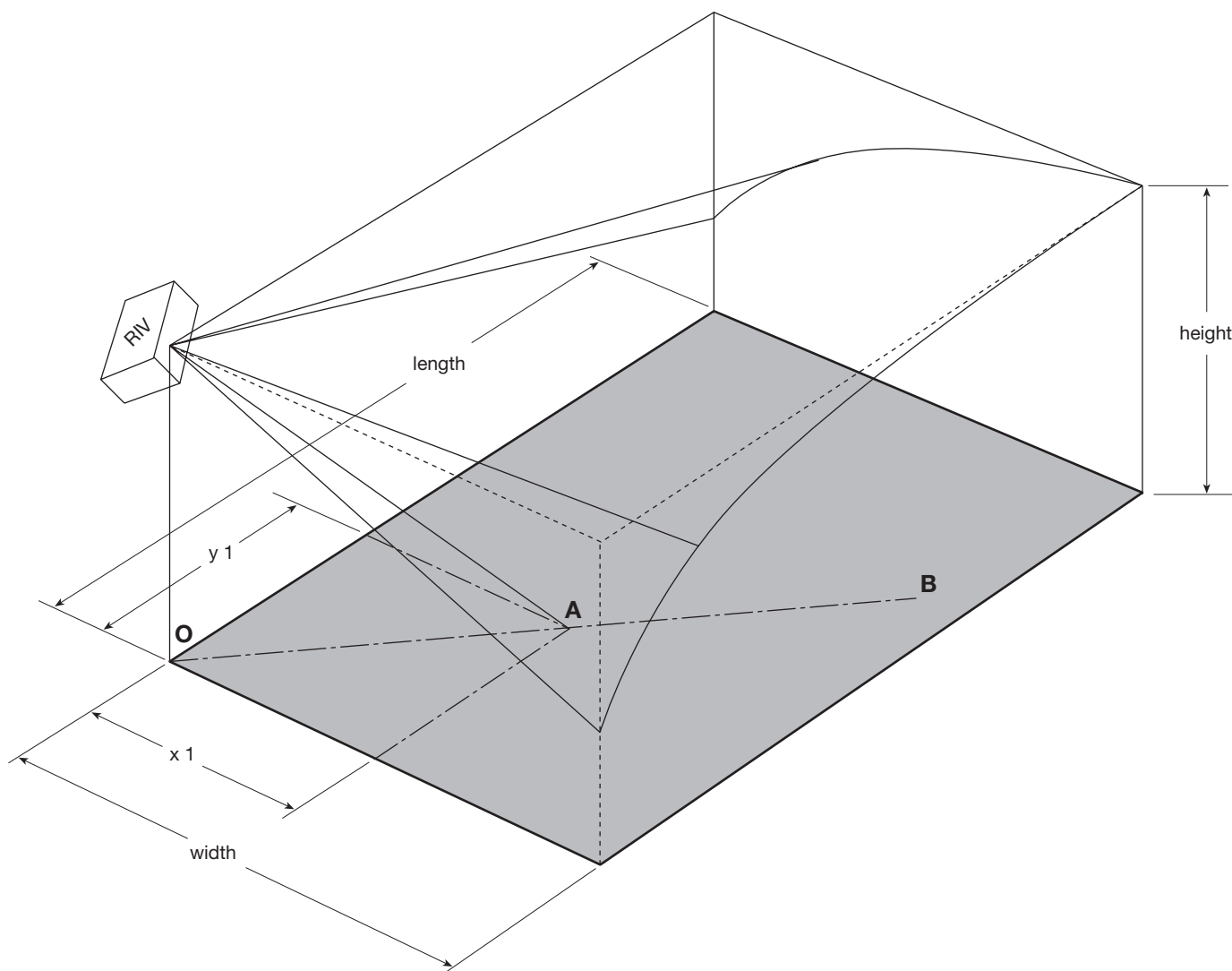

Note:

Remember that the detector sensitivity is 2% of the distance, while 4% for the explosion-proof model

RIV-601P/F IR flame detector applications

D - Vertical application of two detectors with FULL area coverage

When a room cannot be under the field of view of one detector, then the room can be divided into two detection areas, each of them being monitored by one detector mounted vertically on the centre of each area.

This type of application is the double of the "A" type described above, and has a better performance than the "C" type of the previous page.

In the case of a room 10 m high with a floor of 14x28 m the smallest detectable flame size is 20cm on each area centre (2% of 10m distance) and 28cm on each area corner (2% of 14m distance).

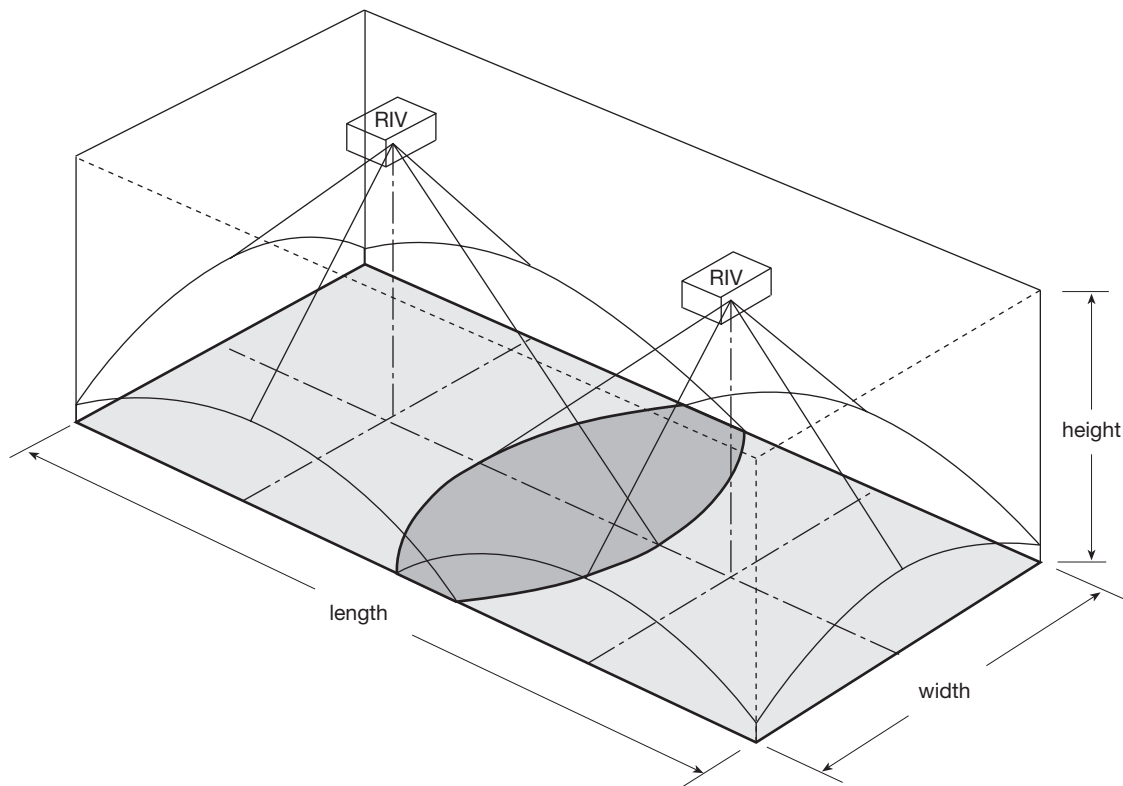

The limit of this application could be a room 10m high with a floor of 20x40m, which has eight small areas on the eight floor corners not fully under the detectors field of view.

Note:

Remember that the detector sensitivity is 2% of the distance, while 4% for the explosion-proof model

RIV-601P/F IR flame detector applications

E - Diagonal application of two detectors with FULL area coverage

In this example of application two detectors are mounted diagonally and perform the monitoring of a big room with both full area coverage and a partial common area for a double checking.

In the first case the room is 10m high and has a floor of 20x40m.

In the second case the room is the same but the two detectors are mounted in a slightly different position.

The disadvantages of the diagonal mounting must be considered before deciding for this solution.

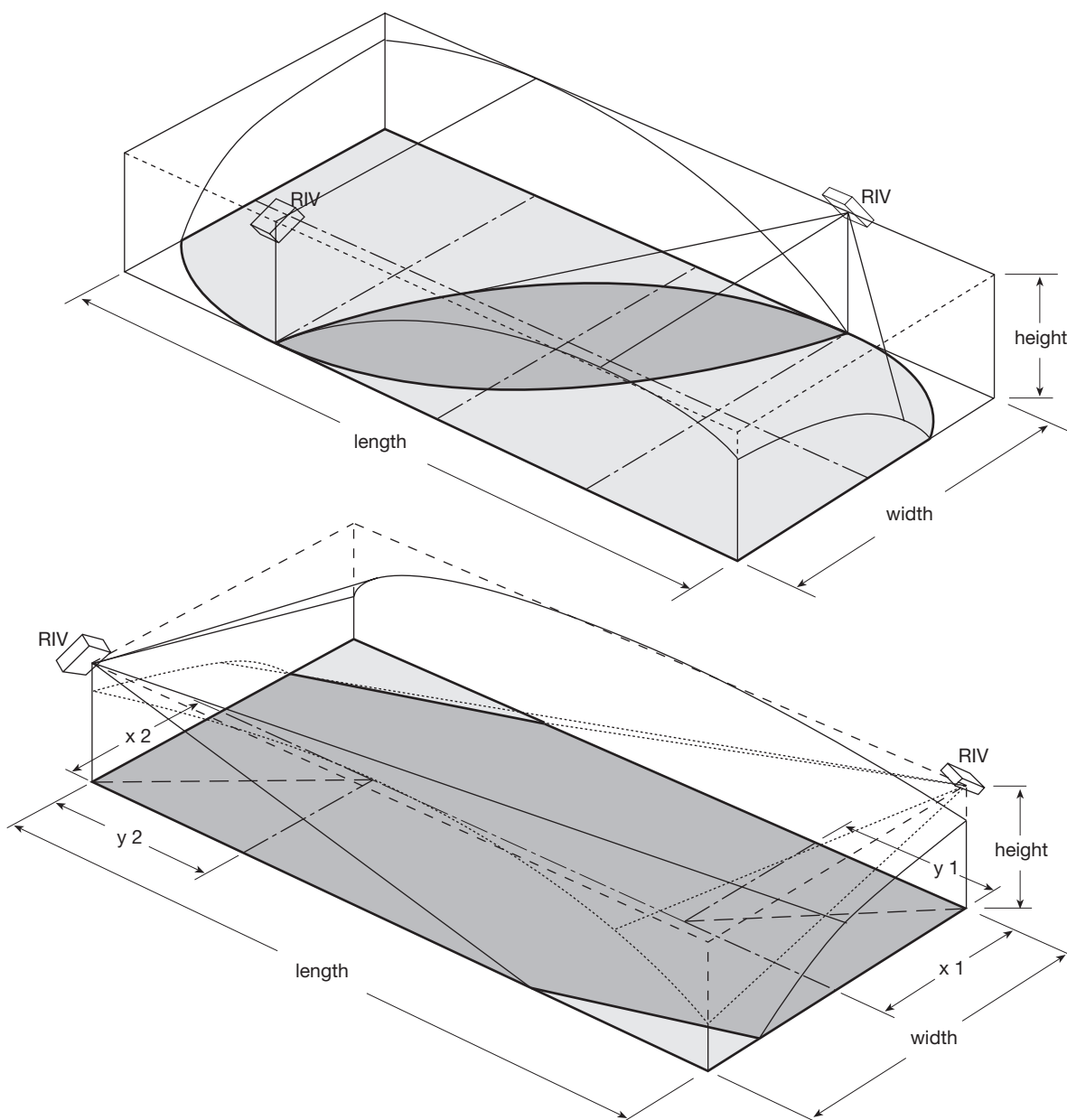

Note:

Remember that the detector sensitivity is 2% of the distance, while 4% for the explosion-proof model

RIV-601P/F IR flame detector applications

F - Vertical application over pole with FULL area coverage

For outdoor applications the rules to be followed are the same as the ones for indoor or room applications. The detector must be mounted vertically looking down.

The elements to be considered are the area surface to be monitored, the height of the pole available, the smallest flame size needed to be detected with 2% detector sensitivity (the smallest flame size is 2% of the distance) and 90° cone field of view.

The floor area diameter is two times as much as the height, and the distance of the floor circle is 1,4 times as much as the height itself. Also, in outdoor applications a roof or cap or an equivalent mechanical protection must be provided in order to prevent both rain or snow to build up over the detector enclosure and to prevent as well the detector from seeing directly the sun or other strong lamps present around, so as to avoid false alarms.

In the case sensitivity is too high for the application, one or more attenuation optical filter can be added on the front of the optical window. These filters can be delivered on demand, free (see page MAFP 19)

Caution must also be taken to design a strong and rigid support to avoid oscillations and vibrations under mechanical shocks and wind pressure.

One practical example is a floor area of 40m in diameter and a 20m high pole.

In this case the smallest detectable flame size is 40cm on the centre (2% of 20m height), and 56cm on the circle (2% of the 28m distance).

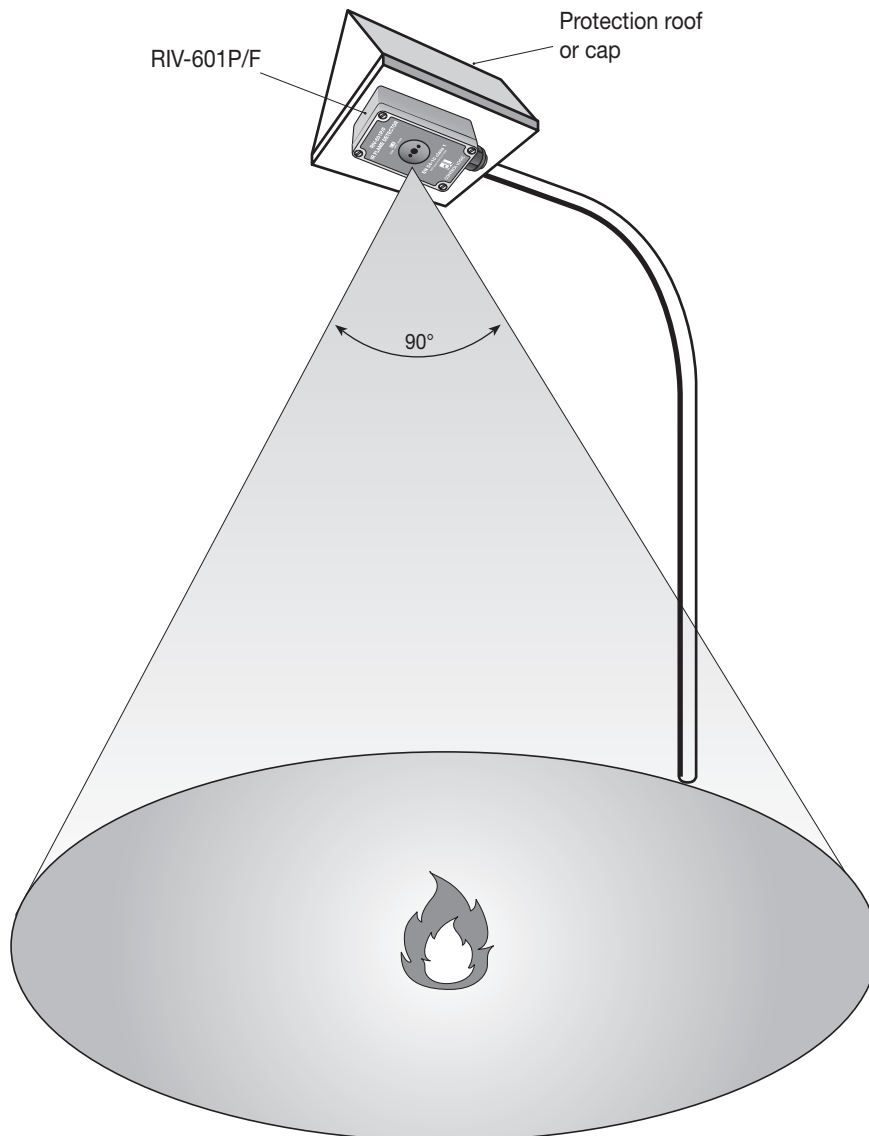

Note:

Remember that the detector sensitivity is 2% of the distance, while 4% for the explosion-proof model

RIV-601P/F IR flame detector electrical connections

The electrical connections are done on 7-way screw type terminal block, plug in type. Each terminal function is printed on the top of every terminal and on the circuit board just before the connector. The input power voltage is 24Vdc nominal value, with an accepted range of 20 to 28Vdc.

The current values are rather low, typically 0.1 to 0.2 Adc. Therefore the wire gauge is only chosen to be strong enough, not for the rated current. A max 1,5 square mm wire gauge is suggested to avoid a difficult wire entry into the screw terminal. Before turning the input power on is highly recommended to check the power voltage value and polarity in order to avoid damage.

Input power:

The 24Vdc power voltage must be entered into the two terminals marked (+) and (-). Pay attention to the polarity, even if an anti-inversion diode is provided on the (+) terminal. Please remember that after the 24Vdc power voltage is applied the detector is disabled and standing by for about 10 seconds (start-up delay) before starting the normal operation and being able to start an alarm.

Output:

- One static output on the "S" terminal from an NPN collector. Normally it is high (+24V). In alarm goes low (+0.1V or higher, depending on the load). Max load 50mA to +24V.
- One changeover SPDT relay contact on the **C-R-L** terminals, rated 1A 30Vdc.
C-R normally closed contact. Opens in alarm.
C-L normally open contact. Closes in alarm.

Test:

The **T +** must be connected to +24V through a normally open pushbutton, which will be depressed for more than 5 sec in order to perform the **manual test** (see the next page). The **T +** terminal must be permanently connected to +24V if the **automatic continuous self test** is wanted (see the next page).

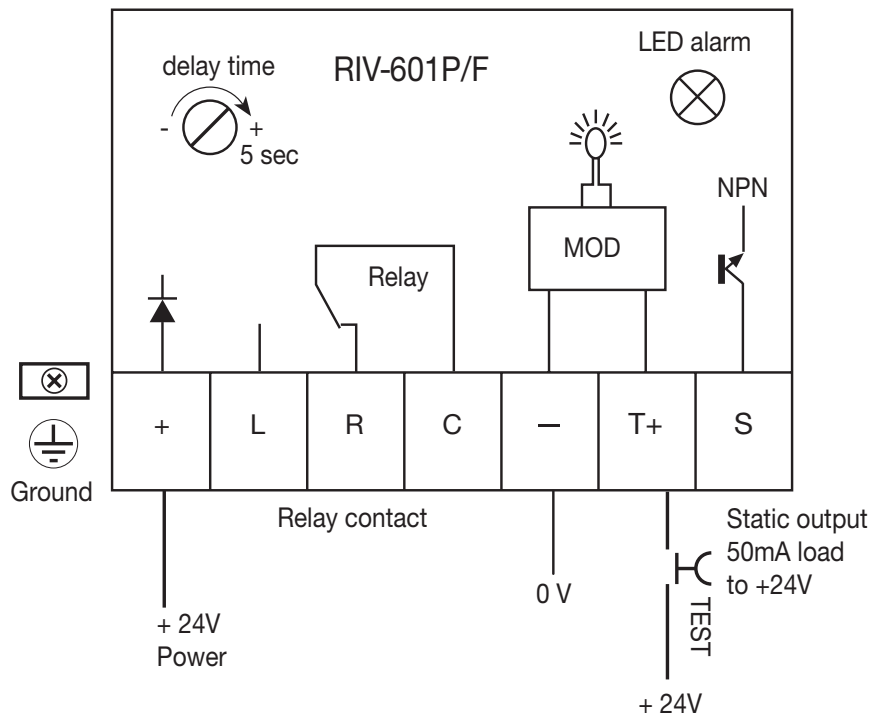

Note:

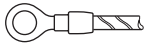
1. It is highly recommended to connect the enclosure base to a good ground line using the **ground** terminal provided inside up on the left. Then, connect base and cover using the ground terminal provided inside the base lower on the right and the ground terminal provided inside the cover lower on the left. All the ground terminals are signaled by ground label.  The ground connection must be done using a yellow-green conductor and a M4 double crimp eyelet.  The yellow-green ground conductor must be longer than the other conductors.
2. In order to ensure an **IP66 protection grade** the cover must be tightly closed turning the four screws provided. The suggested closing torque value is 1 ÷ 1,5 Nm.

RIV-601P/F IR flame detector remote test function

The **test** function makes it possible to remotely monitor the full detector operation both in **alarm** state or if **faulty**. This function is performed by powering a small incandescent bulb placed near the infrared sensor inside the detector. The bulb light is made pulsing by a built-in modulator circuit, in order to simulate a real flame.

If the test is held on for more than 5 seconds, then the detector goes into the alarm state just for a small time of 0.5 seconds, then it restarts the waiting cycle of 5 seconds. During all the time the test is on, the detector outputs a small alarm pulse of 0.5 second every 5 seconds. During this test pulse the front LED lamp is lighted for 0.5 seconds, the **S** terminal goes low for 0.5 seconds, and the relay contact too is activated for 0.5 seconds, i.e., the normally closed contact (**C-R**) opens for 0.5 seconds, and the normally open contact (**C-L**) closes for 0.5 seconds. If the detector is faulty, it does not respond to the test function, and no test pulse is generated. Therefore the test pulses do mean the detector is healthy, instead the absence of test pulses do mean the detector is faulty.

Please remember that this internal test does not allow to check the detector optical window integrity from a dust or dirt build-up but only the electronic circuit operation. Then if the optical window is dirty, the sensitivity is reduced, and the fire could not be detected, even if the test is ok. Anywhere, a small dust or dirt amount does not make the detector blind.

To externally check the detector, a cigarette lighter could be lighted in front of the detector, but it must be waived in order to create a real fire flame. For an automatic optical window integrity checking, the optional LAM-612 unit could be used, which will generate the test pulsing light from an external position to the detector window.

Manual test

The **T+** terminal is connected to +24V through a normally open test pushbutton. Hold the push button on for at least 10-20 seconds. After 5 seconds the detector gives a short 0.5 seconds alarm pulse, then restarts and waits another 5 seconds to give a second 0.5 seconds pulse, etc., for as long as the pushbutton is held closed. As soon as the pushbutton returns open the test cycle is reset. During the manual test the alarm panel must disable all alarm outputs, or it must be able to recognise the short pulses only as a healthy detector state, since the fire alarm state is longer, at least 5 seconds.

Automatic test

The **T+** terminal is wired to (+) terminal (+24 V). After the 5 seconds initial delay time the test pulses cycles are started. One 0.5 seconds alarm pulse is given every 5 seconds time period. In this case the alarm panel must be able to recognise the short pulses only as a healthy detector state, since the fire alarm state lasts longer, at least 5 seconds, in order to provide a fault warning signal if the test pulses are discontinued.

With a standard alarm panel which cannot be programmed to recognise the test pulses, a more standard solution is suggested, as described in the following page, in which the test is used to cause a line short circuit fault warning signal.

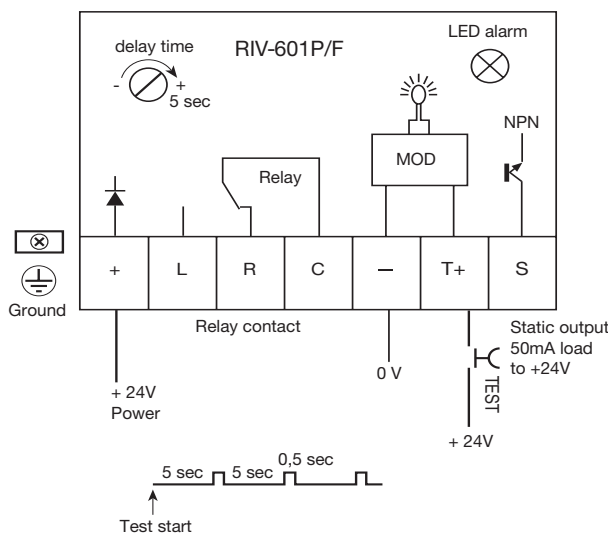

Manual test

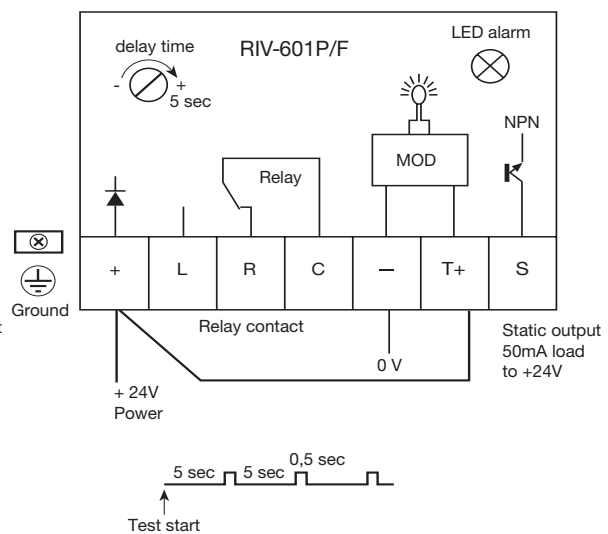

Automatic test

RIV-601P/F

IR flame detector automatic remote fault warning

Electrical connections to a standard fire alarm panel

Both the normally open (**C-L**) and the normally closed (**C-R**) relay contacts are used.

The normally open contact (**C-L**) is used for the fire alarm and provides the line current determined from the R1 and R2 resistors parallel.

The normally closed contact (**C-R**) is used for the fault warning signal (detector always OFF or 24Vdc power voltage OFF).

Since during the automatic test the detector generates a short 0.5 seconds pulse every 5 seconds (**C-L** closes for 0.5 seconds and **C-R** opens for 0.5 seconds) the L1 line must be delayed for at least 5-10 seconds before giving a fire alarm signal when **C-L** closes.

The fault warning signal must be delayed for at least 10-20 seconds before the **C-R** closure can be considered a fault.

Every 5 seconds the **C-R** contact opens for 0.5 seconds, and the delay time is reset.

Note:

The two standard fault warning signals are still available:

- open line fault
- short circuit line fault

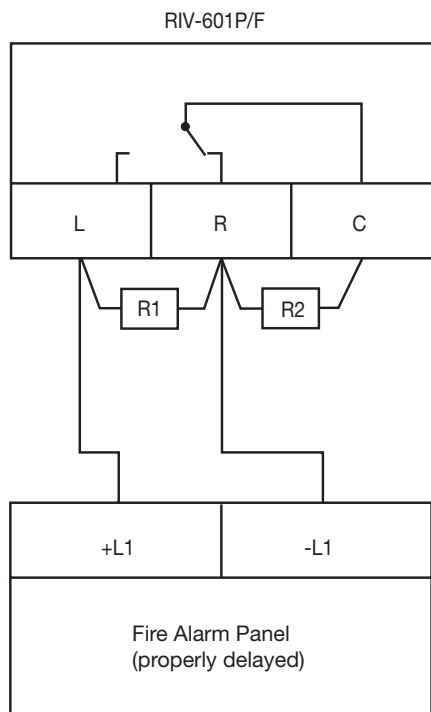

R1 = End of line resistor, which creates the stand by line current.
Typical value 3k3 0.5W (see your fire alarm panel instructions)

R2 = Alarm current limiting resistor.
Typical value 3k3 0.5W (see your fire alarm panel instructions)

L1 = Alarm line.

FIL 39G attenuation optical filter

Sometimes the presence of strong noise, coming from sun or incandescent lights modulated by moving trees or other things, that cannot be avoided by changing the detector position, needs to decrease the detector sensitivity in order to avoid false alarms. For this purpose one or more attenuation optical filters are provided, which do reduce the detector sensitivity.

These optical filters are yellow adhesive plastic (poly-carbonate) discs, 39mm in diameter and 0.25mm thick, that can be placed externally over the optical window.

The sensitivity reduction prevents the detector from issuing false alarms, still assuring a good sensitivity level.

One filter disc decreases the detector sensitivity from the standard value of 2% to 3%.

Then the smallest detectable flame size becomes 3% of the distance. This means that at a 10m distance the smallest detectable flame size is increased from 20cm to 30cm.

With two filter discs the sensitivity becomes 4% of the distance, that is, at a 10m distance the smallest detectable flame size is 40cm.

With three filter discs the sensitivity becomes 6%, that is, at a 10m distance the smallest detectable flame size is 60cm.

When needed, usually only one filter disc is used. The use of more than three filter discs is wrong.

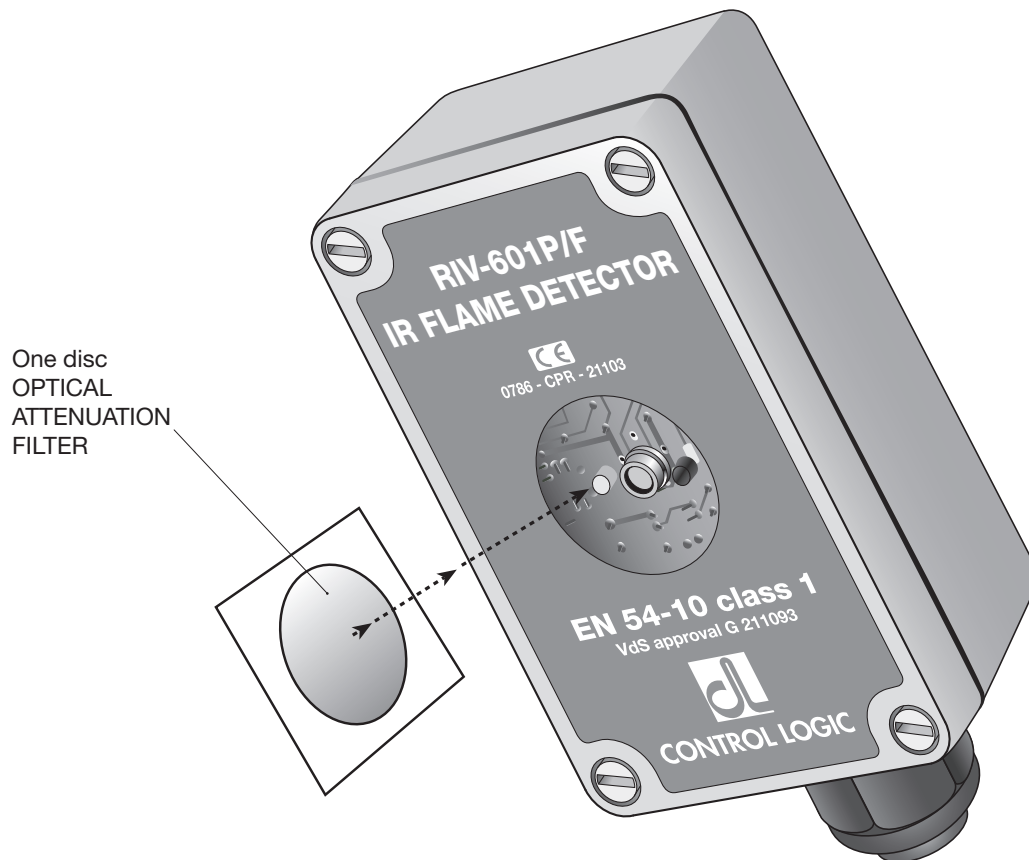

SOR-876 VARIABLE DIRECTION STAND for IR Flame Detector RIV-601P/F

Description

The Variable Direction Stand SOR-876 is a useful accessory for installing IR Flame Detector RIV-601P/F when an easy change of direction of the optical field of view toward the area of interest is needed.

It is composed of a steering arm fully adjustable on all axes and of a base plate designed for IR Flame Detector RIV-601P/F mounting. Both the steering arm and the base plate are made of aluminium, screw parts are of stainless steel, and can be used in outdoor applications.

Specifications

- Multiple adjustable on all axes with 4 joints
- Wall and ceiling mounting
- Steering arm material: die-cast aluminium powder coated black paint
- Base plate material: aluminium powder coated black paint
- Packaging 155x145x120mm containing:
 - 1 steering arm complete with base plate
 - 4 screws M4x25 with washers for Flame Detector mounting
 - 1 hex key
 - 1 datasheet
- Total weight kg 0.7 net – kg 0.8 gross



Ceiling mounting

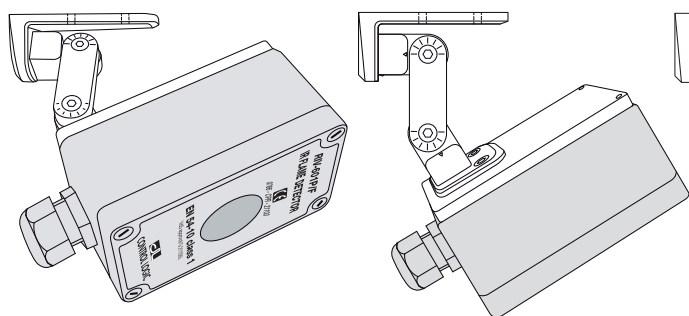

Wall mounting

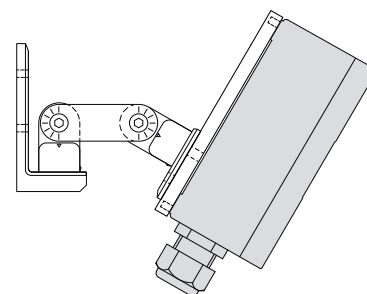

Mechanical dimensions (mm)

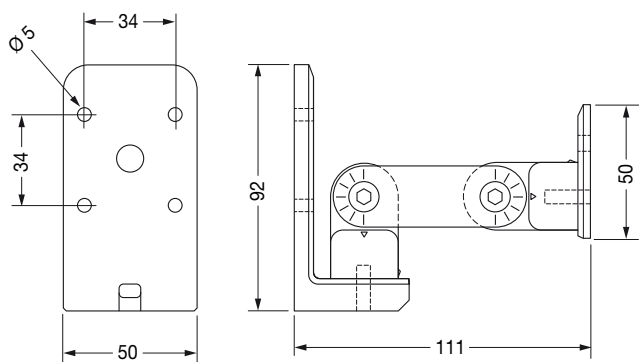

Steering arm

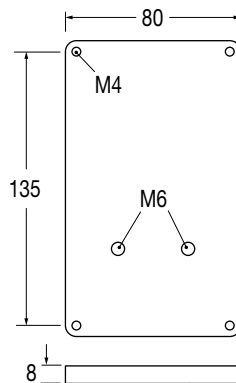

Base plate

Plate adjustment screw

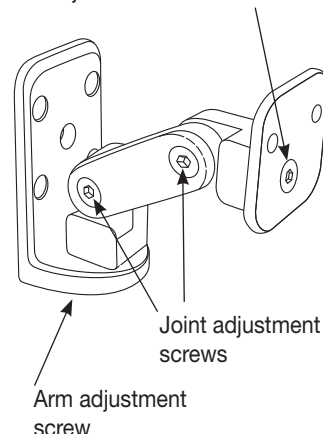



Zertifikat Certificate

Anerkennung von Bauteilen und Systemen Approval of Components and Systems



Inhaber der Anerkennung
Holder of the Approval
CONTROL LOGIC s.r.l.
Via Ennio 25
IT-20137 Milano

Die Anerkennung

umfasst nur das angegebene Bauteil/System in der zur Prüfung eingereichten Ausführung

- mit den Bestandteilen nach Anlage 1,
- dokumentiert in den technischen Unterlagen nach Anlage 2,
- zur Verwendung in den angegebenen Einrichtungen der Brandschutz- und Sicherungstechnik.

Bei der Anwendung des Gegenstandes der Anerkennung sind die Hinweise nach Anlage 3 zu beachten.

Das Zertifikat darf nur unverändert und mit sämtlichen Anlagen vervielfältigt werden. Alle Änderungen der Voraussetzungen für die Anerkennung sind der VdS-Zertifizierungsstelle - mitsamt den erforderlichen Unterlagen - unverzüglich zu übermitteln.

This Approval

is valid only for the specified component/system as submitted for testing

- together with the parts listed in enclosure 1
- documented in the technical documents according to enclosure 2
- for the use in the specified fire protection and security installations.

When using the subject of the approval the notes of enclosure 3 shall be observed.

This certificate may only be reproduced in its present form without any modifications including all enclosures. All changes of the underlying conditions of this approval shall be reported at once to the VdS certification body including the required documentation.

VdS Schadenverhütung GmbH
Zertifizierungsstelle
Amsterdamer Str. 174
D-50735 Köln

Ein Unternehmen des Gesamtverbandes der Deutschen Versicherungswirtschaft e.V. (GDV), durch die DAkkS akkreditiert als Zertifizierungsstelle für Produkte in den Bereichen Brandschutz und Sicherungstechnik

A company of the German Insurance Association (GDV) accredited by DAkkS as certification body for fire protection and security products

Anerkennungs-Nr. Approval No.	Anzahl der Seiten No. of pages	gültig vom valid from	gültig bis valid until
G 211093	4	20.12.2015	13.06.2018

Gegenstand der Anerkennung
Subject of the Approval
IR-Flammenmelder/ IR flame detector
RIV-601P/F

Verwendung
Use
in automatischen Brandmeldeanlagen
in automatic fire detection and fire alarm systems

Anerkennungsgrundlagen
Basis of the Approval
VdS 2344:2014-07
VdS 2504:1996-12 / 5.6
EN 54-10:2002 + A1:2005

Köln, den 12.02.2016

Dr. Reinermann

Geschäftsführer
Managing Director

i. V. Hesels

Leiter der Zertifizierungsstelle
Head of Certification Body





VdS Schadenverhütung GmbH • Amsterdamer Straße 172-174 • D-50735 Köln

Notifizierte Zertifizierungsstelle für Bauprodukte • Kenn-Nummer 0786
Notified Certification Body for Construction Products • Registration No. 0786

EG-Konformitätszertifikat EC-Certificate of Conformity

0786 – CPD - 21103

Gemäß der Richtlinie 89/106/EWG des Rates der Europäischen Gemeinschaften vom 21. Dezember 1988 zur Angleichung der Rechts- und Verwaltungsvorschriften der Mitgliedstaaten über Bauprodukte (Bauproduktenrichtlinie – CPD), geändert durch die Richtlinie 93/68/EWG des Rates der Europäischen Gemeinschaften vom 22. Juli 1993, wird hiermit bestätigt, dass das Bauprodukt

In compliance with the Directive 89/106/EEC of the Council of European Communities of 21 December 1988 on the approximation of laws, regulations and administrative provisions of the Member States relating to the construction products (Construction Products Directive - CPD), amended by the Directive 93/68/EEC of the Council of European Communities of 22 July 1993, it has been stated that the construction product

**IR-Flammenmelder
RIV-601P/F**

**IR flame detector
RIV-601P/F**

(Produktmerkmale siehe Anlage 1)

(Product parameters see appendix 1)

in Verkehr gebracht durch

placed on the market by

**CONTROL LOGIC s.r.l.
Via Ennio 25
IT 20137 Milano**

und erzeugt im Herstellwerk

and produced in the factory

**CONTROL LOGIC s.r.l.
Via Ennio 25
IT 20137 Milano**

durch den Hersteller einer werkseigenen Produktionskontrolle sowie zusätzlichen Prüfungen von im Werk entnommenen Proben nach festgelegtem Prüfplan unterzogen wird und dass die notifizierte Stelle VdS Schadenverhütung GmbH eine Erstprüfung der relevanten Eigenschaften des Produkts, eine Erstinspektion des Werkes und der werkseigenen Produktionskontrolle durchgeführt hat und eine laufende Überwachung, Beurteilung und Anerkennung der werkseigenen Produktionskontrolle durchführt.

Dieses Zertifikat bescheinigt, dass alle Vorschriften über die Bescheinigung der Konformität und die Leistungseigenschaften, beschrieben im Anhang ZA der Norm(en)

is submitted by the manufacturer to a factory production control and to the further testing of samples taken at the factory in accordance with a prescribed test plan and that the notified body VdS Schadenverhütung GmbH has performed the initial type-testing for the relevant characteristics of the product, the initial inspection of the factory and of the factory production control and performs the continuous surveillance, assessment and approval of the factory production control.

This certificate attests that all provisions concerning the attestation of conformity and the performances described in the Annex ZA of the standard

EN 54-10:2002 + A1:2005

angewendet wurden und dass das Produkt alle darin vorgeschriebenen Anforderungen erfüllt.

Dieses Zertifikat wurde erstmals am 22.12.2011 ausgestellt und gilt solange, wie die Festlegungen in der angeführten harmonisierten technischen Spezifikation oder die Herstellbedingungen im Werk oder die werkseigene Produktionskontrolle selbst nicht wesentlich verändert werden.

were applied and that the product fulfils all the prescribed requirements.

This certificate was first issued on 22.12.2011 and remains valid as long as the conditions laid down in the harmonised technical specification in reference or the manufacturing conditions in the factory or the FPC itself are not modified significantly.

Köln, 22.12.2011

(i.V. Hesels)

Leiter der Zertifizierungsstelle
Head of Certification Body



Via Ennio, 25 - 20137 Milano - Italy
Tel. +39 02 5410 0818 r.a. - Fax +39 02 5410 0764
E-mail: controllogic@controllogic.it - Web: www.controllogic.it



CONTROL LOGIC S.r.l.